

Forward Calorimeters for the ILC

Arno Straessner

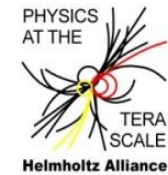

- FCAL Challenges at ILC
- Sub-Detectors and Ongoing R&D
 - Outlook

2nd Helmholtz Alliance Detector Workshop
DESY
March 2009

Forward Calorimeters at the ILC

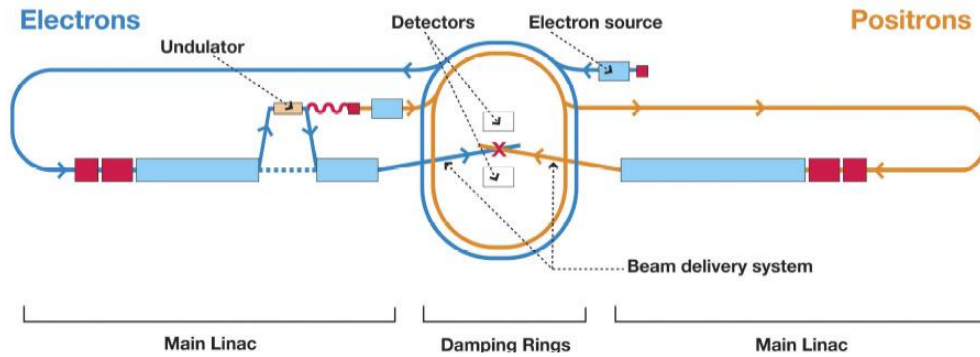

500 GeV centre-of-mass energy
 Luminosity $2 \times 10^{34} \text{ cm}^{-2} \text{ s}^{-1}$
 Polarization e- 80% e+ 30% (60%)
 Beam $\sigma_x \sim 600 \text{ nm}$ $\sigma_y \sim 6 \text{ nm}$ $\sigma_z \sim 300 \text{ } \mu\text{m}$

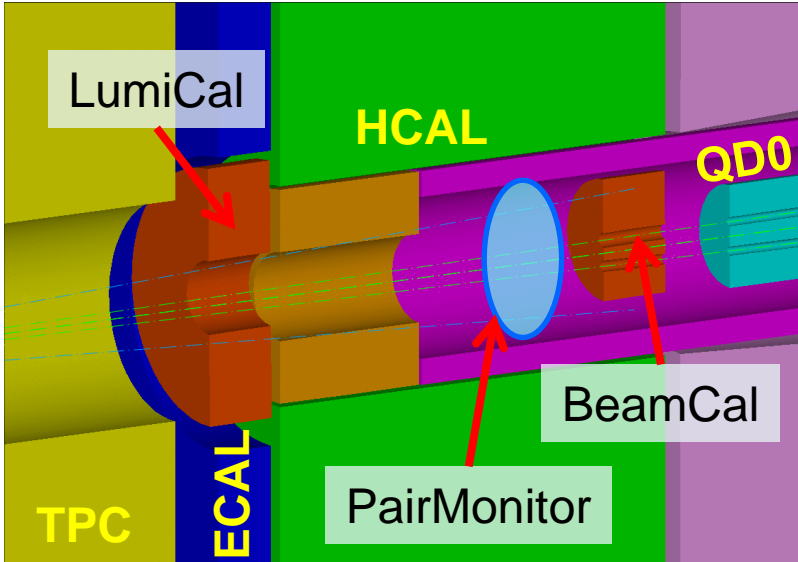

- 4 main very-forward detectors:
- LumiCal at 44-155 mrad
 → luminosity measurement ($\Delta L/L \sim 10^{-3} - 10^{-4}$)
- BeamCal at 5-45 mrad
 → fast beam diagnostics & feedback
 → electron veto
- Pair Monitor (1st layer of BeamCal)
 → beam parameter determination by measuring e^+e^- from beam-beam interactions
- GamCal at 100m distance to IP
 → beam diagnostics with beamstrahlung photons

- Luminosity measurement using Bhabha events $e^+e^- \rightarrow e^+e^-$ like at LEP: $L \sim N/\sigma_{\text{theory}}$
- Cross-section $\sim \theta^{-3} \rightarrow$ precise fiducial volume and small angular bias

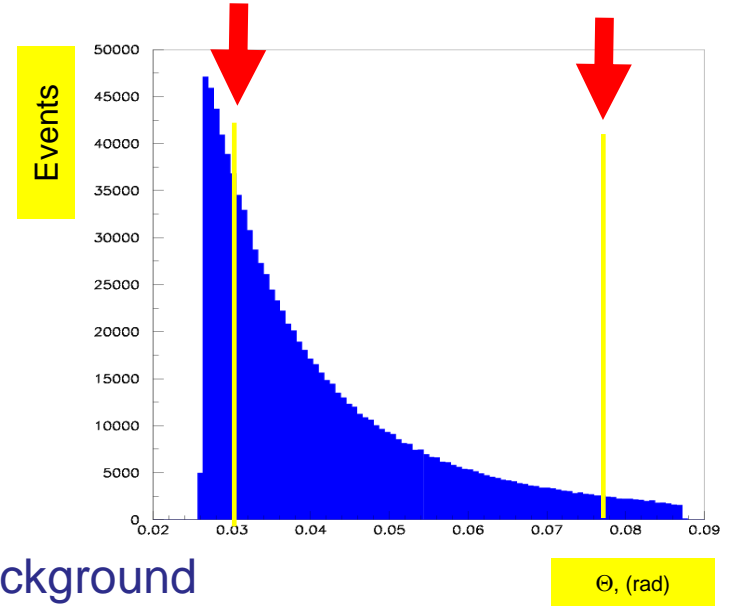
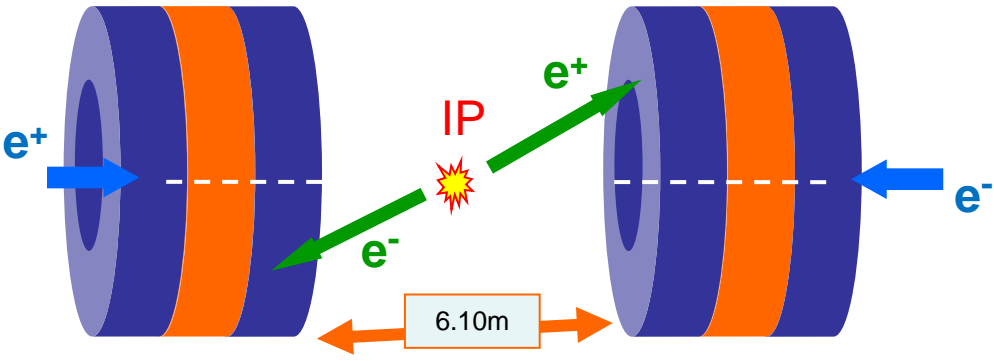

- Compact calorimeter \rightarrow small Moliere radius
- Well measured energy scale $\sim 0.1\%$
 \rightarrow reduce radiative events and two-photon background

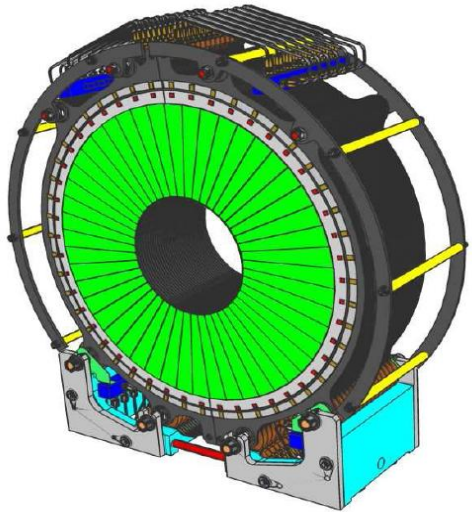

- W/Si sandwich calorimeter with 30 layers
- 3 mm tungsten absorbers
- 300 μm Si sensors
- 64 radial and 48 azimuthal divisions

LumiCal Sensors

Silicon sensor half plane

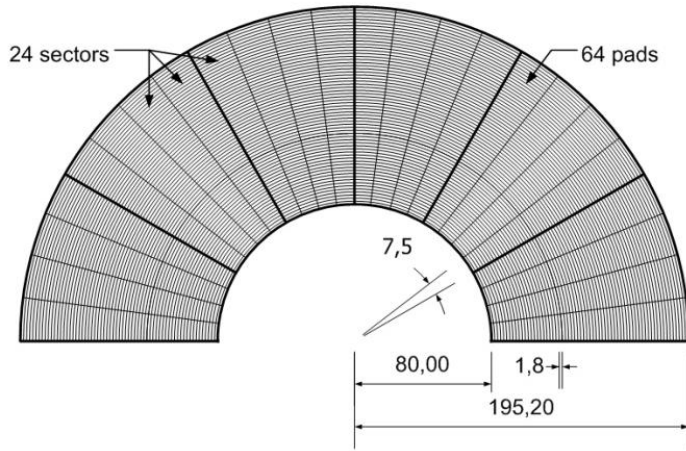

- n-type silicon, p+ strips, n+ backplane
- 320 μm thickness $\pm 15 \mu\text{m}$
- Strip pitch: 1.8 mm
- Strip p+ width: 1.6 mm
- Strip Al width: 1.7 mm
- Prototype produced by Hamamatsu arrived in March
- Measurement of the sensor characteristics started
- In parallel: development of the fanout

First Prototype

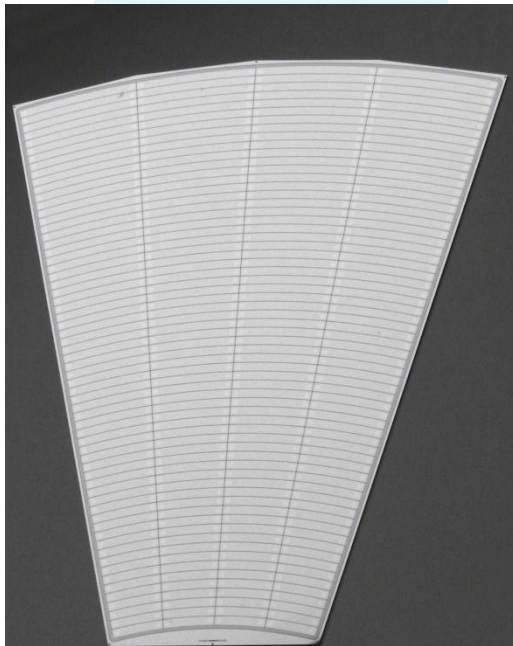

Fanout prototype on PCB test sector

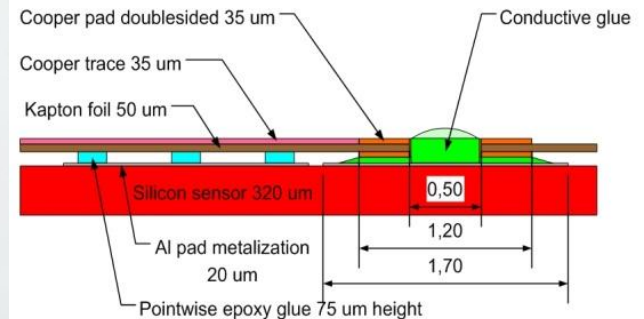
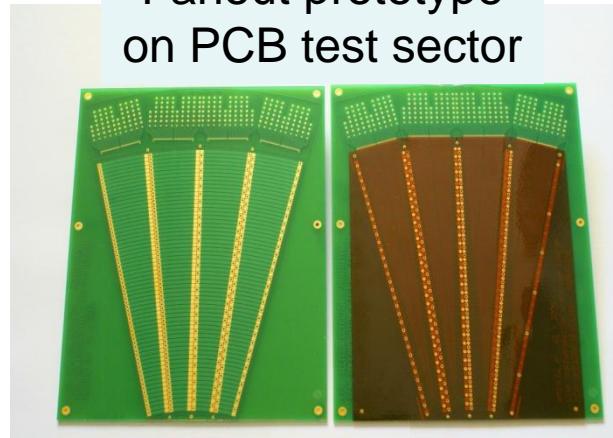

Bump bonding

LumiCal Front-end



- 200000 readout channels
- R&D goal: ~1000 channels (now: a few)
- 0.35 μm CMOS ASICs
- first frontend and ADC prototypes tested
- Pre-amp, pole zero cancellation, shaper
- Active MOS and passive R feedback with similar results in physics mode
- 10-bit pipelined ADC 1.5 bit/stage

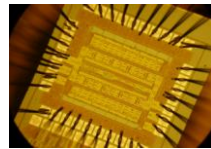
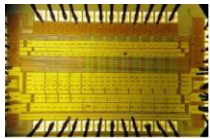
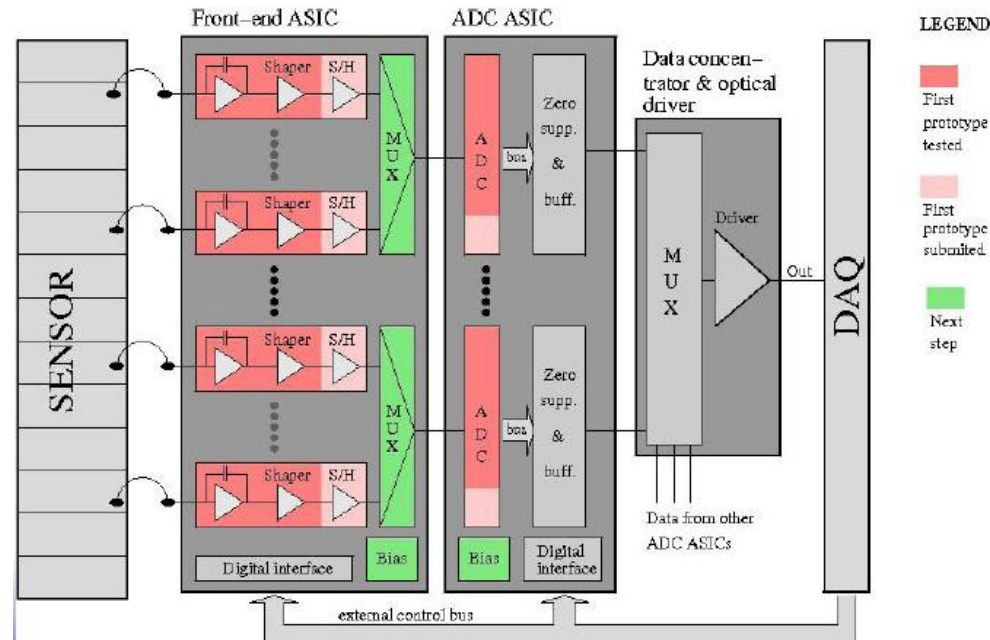

Physics mode

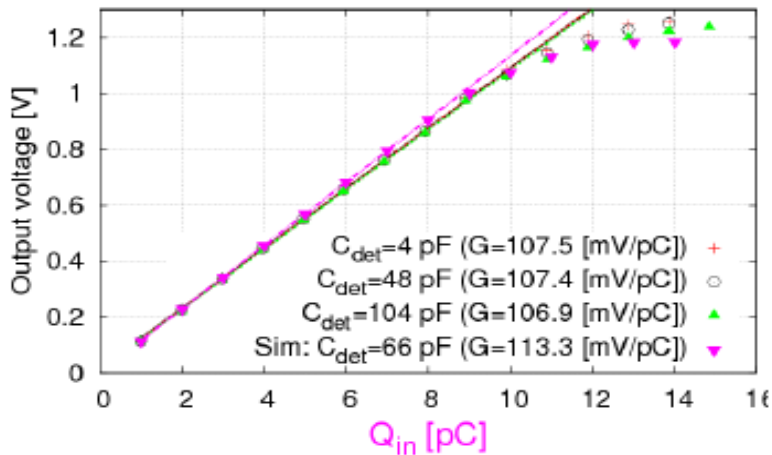

gain test results with different detector capacitance

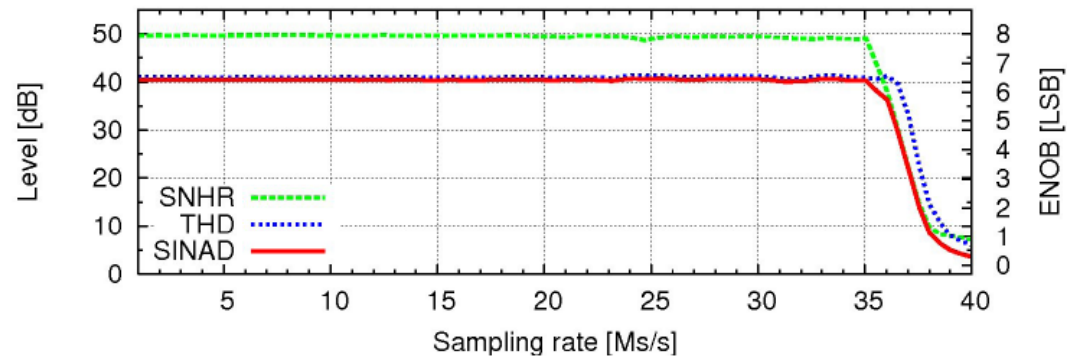

ADC dynamic performance
→ more work needed (stage nonlinearities)

LumiCal Front-end



- First successful test of the analog front-end with a single-pad sensor

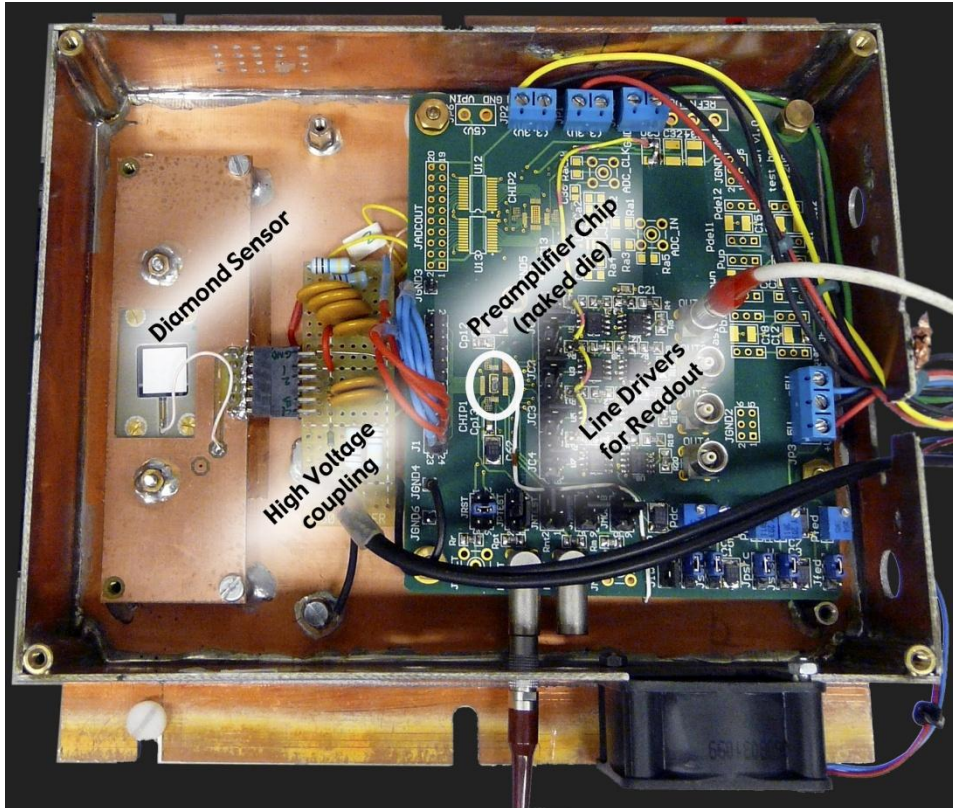

Si detector, MOS preamp.

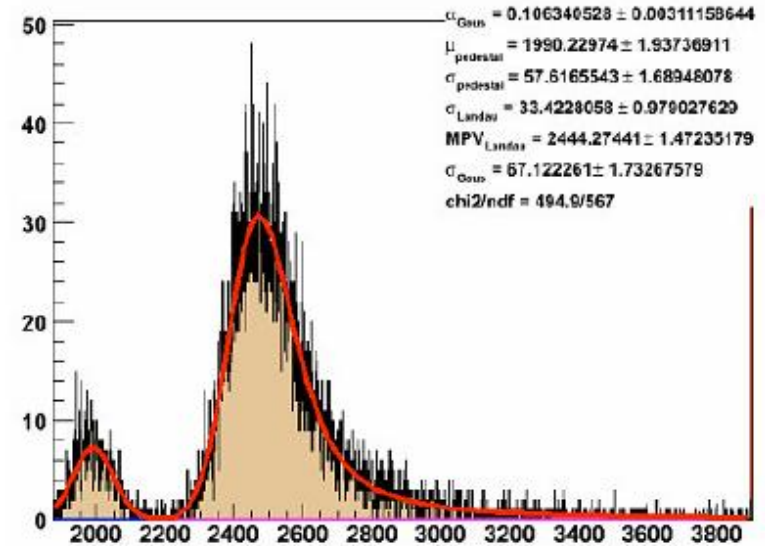

- Luminosity can be optimised by measuring e^+e^- pairs (BeamCal/Pair Monitor) and beamstrahlung photons (GamCal) → fast readout and feedback loop

Example:

Vertical offset

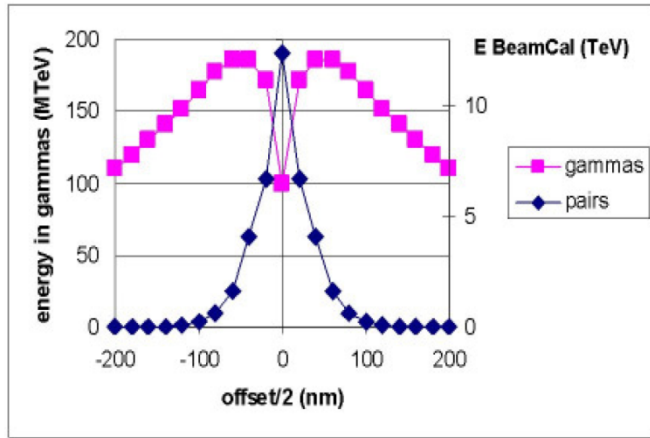

Ratio of Energies (BCAL)

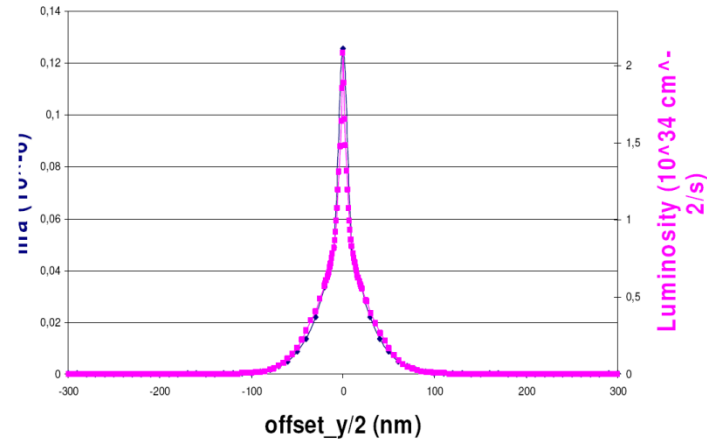

- BeamCal shall tag forward electrons from two-photon processes as background to SUSY:

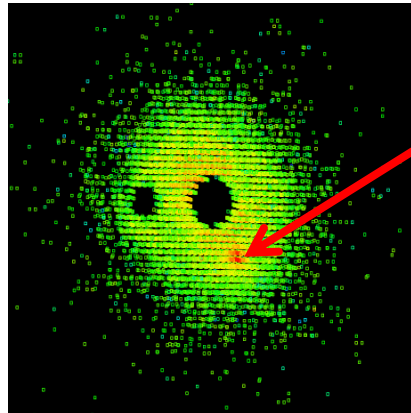
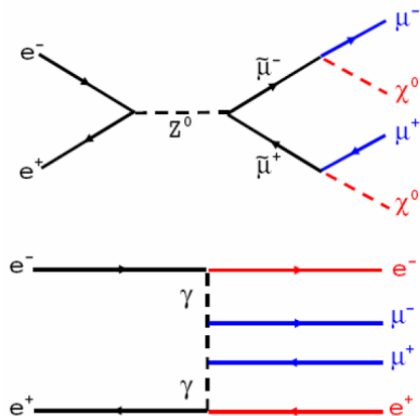

Identify single electron in background of 10^4 beamstrahlung pairs

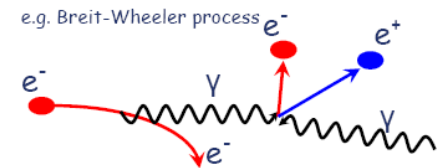

→ high radiation dose 10 MGy/a

BeamCal Design

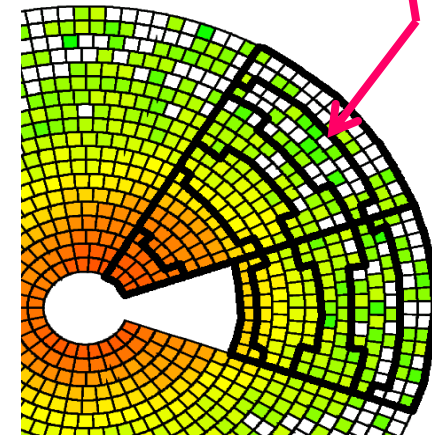
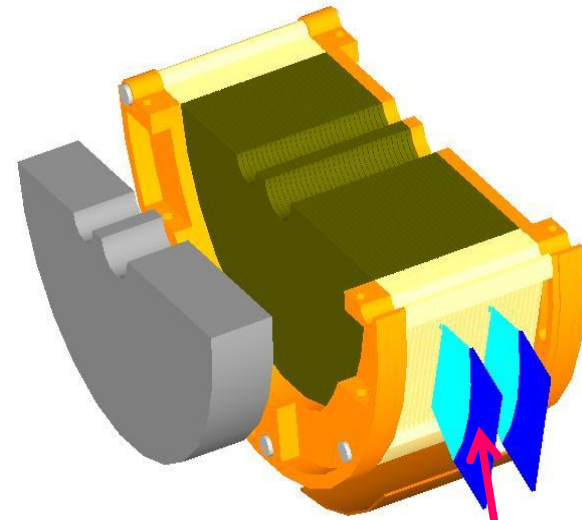
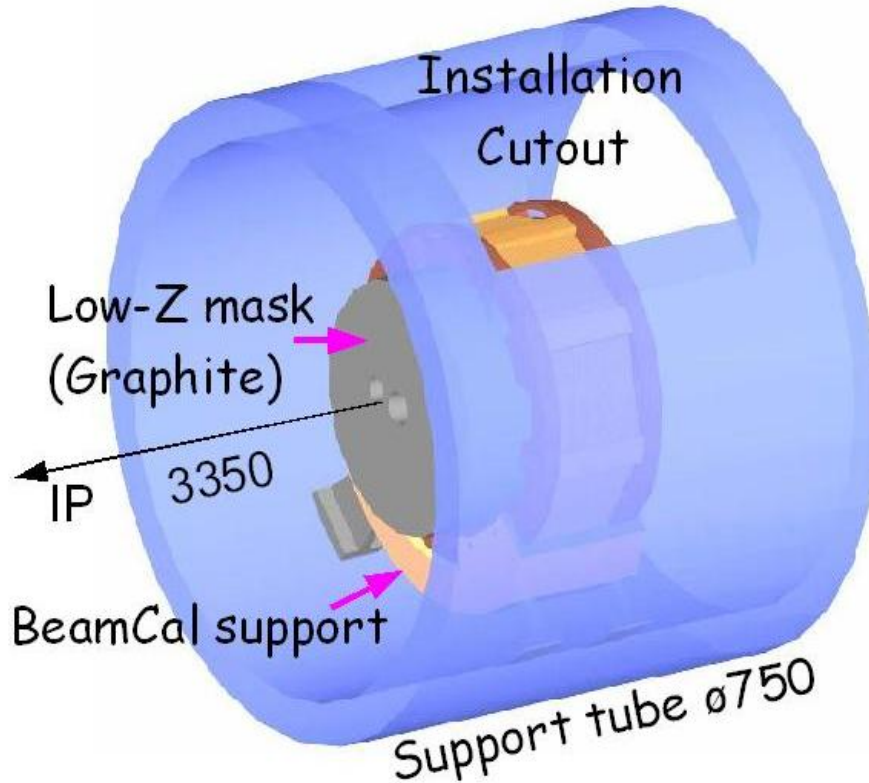

FE electronics for fast analog sums and read-out

- W sandwich calorimeter with 30 layers
- 3 mm tungsten absorbers
- 8 radial sectors with 1280 channels each

- pCVD diamonds:
- radiation hardness under investigation (e.g. LHC beam monitors, pixel detectors)
- GaAs:
- semi-insulating GaAs, doped with Sn and compensated by Cr
- SC CVD diamonds:
- available in sizes of mm²
- Sapphire (Al₂O₃) and Quartz (SiO₂)

CVD: Chemical Vapor Deposition

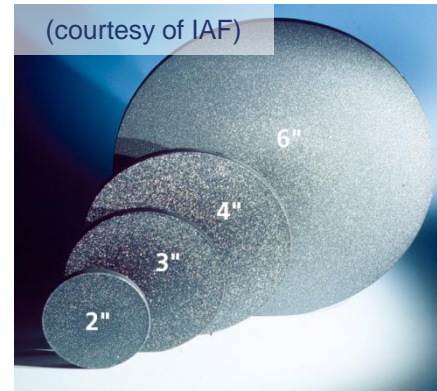

polycrystalline
CVD diamond

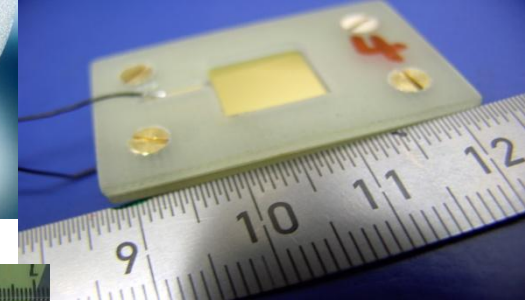

GaAs

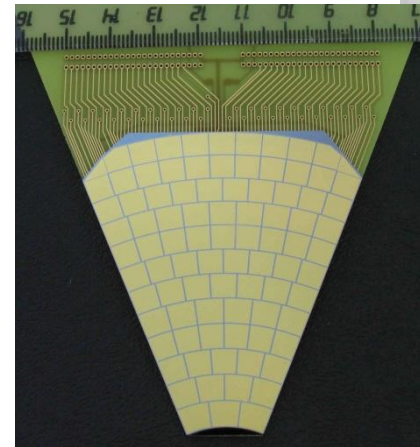

Single crystal
CVD diamond

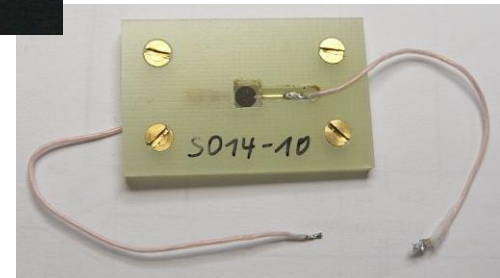

Irradiation tests at TU Darmstadt SDALINAC

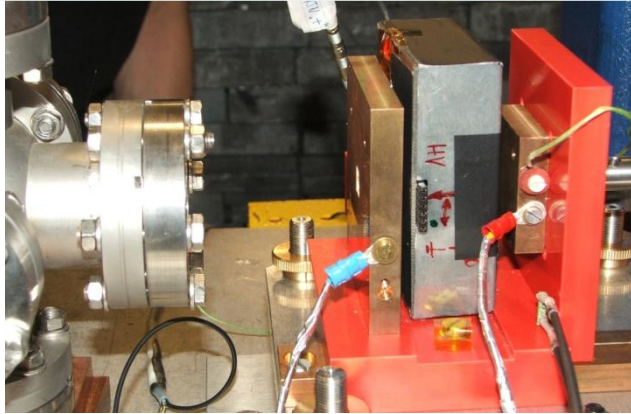

Charge Collection Depth vs. dose for pCVD diamond

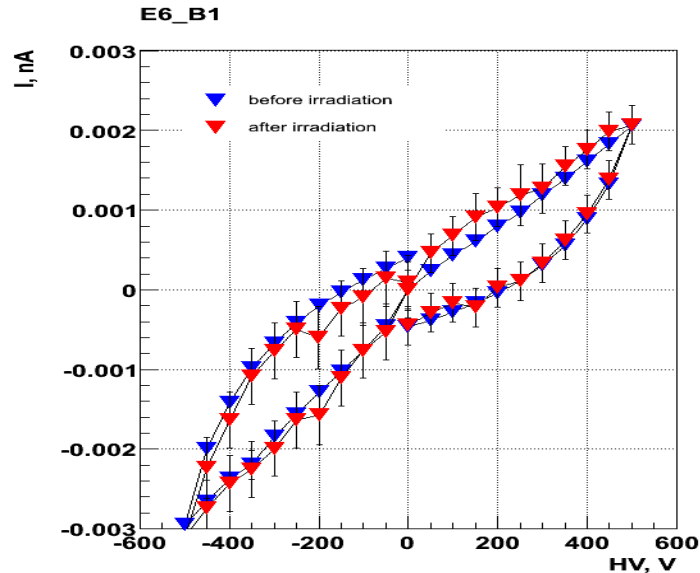
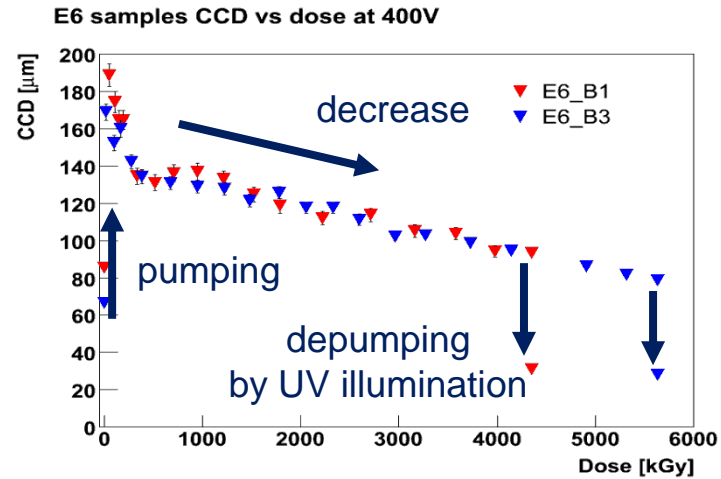

No increase of leakage current
(at room temperature)

Irradiation tests at TU Darmstadt SDALINAC

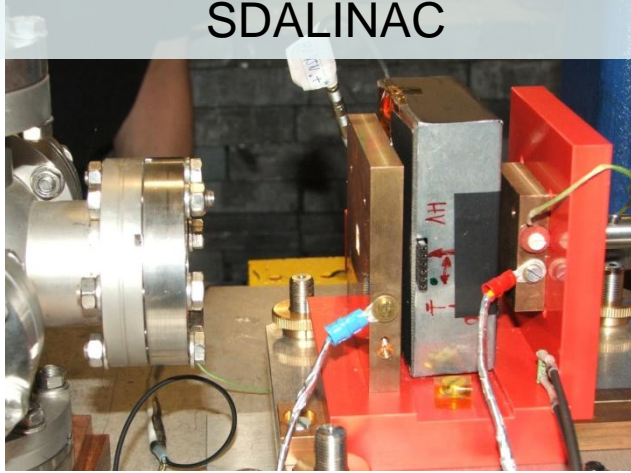

Charge Collection Depth vs. dose for GaAs

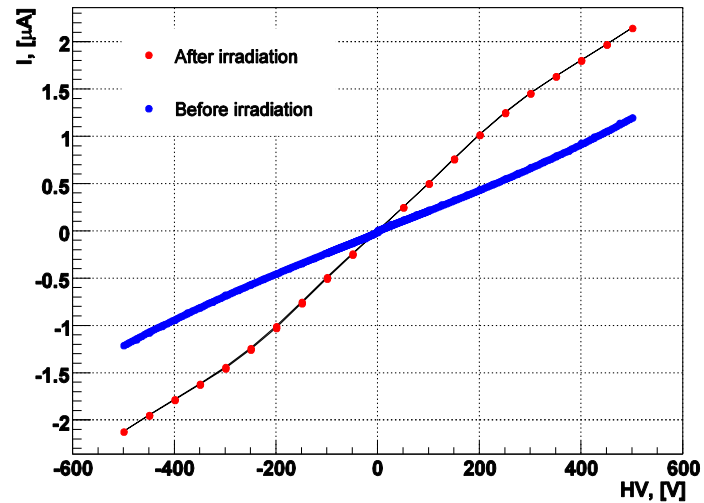
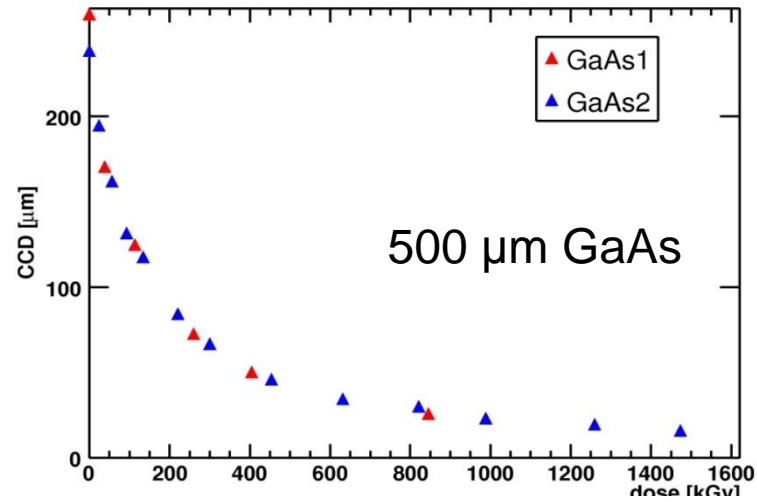

Acceptable increase of leakage current

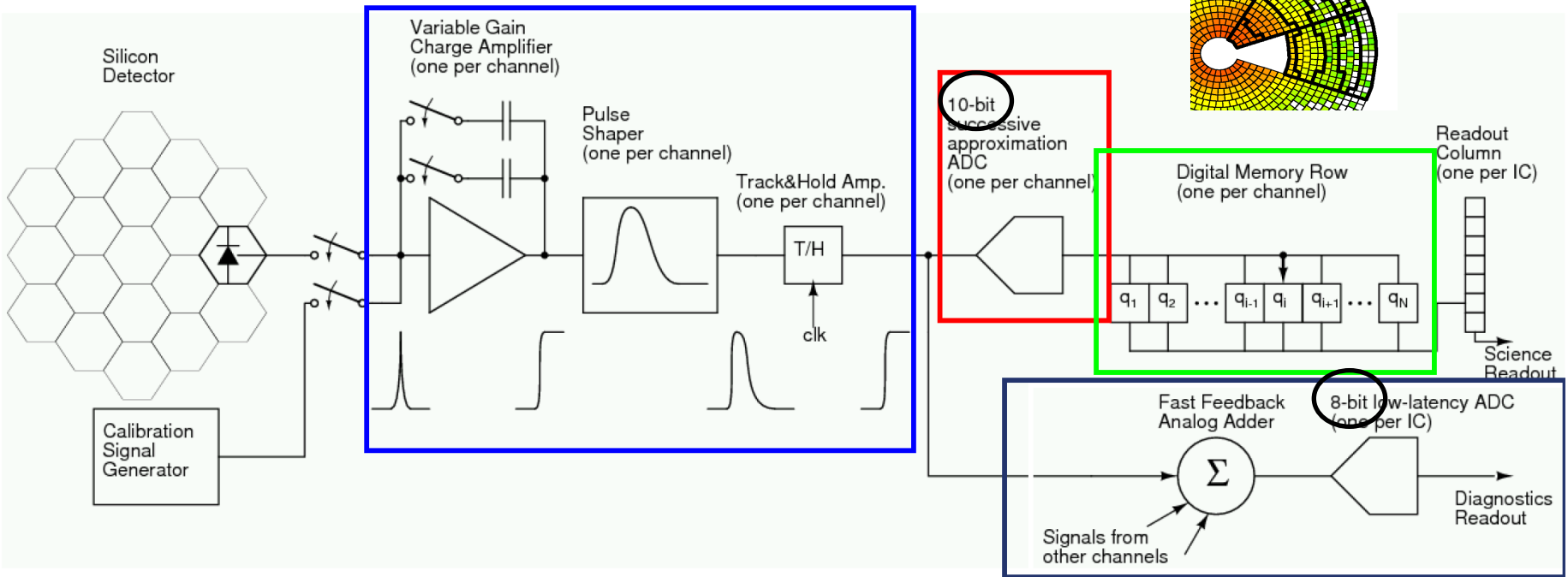
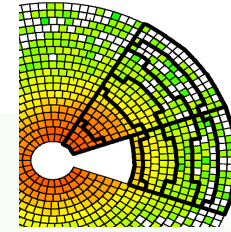

- Dual-gain front-end electronics: charge amplifier, pulse shaper and T/H circuit
- **Successive approximation ADC, one per channel**
- **Digital memory, 2820 (10 bits + parity) words per channel**
- Analog addition of 32 channel outputs for fast feedback; low-latency ADC

Prototype in 0.18- μm TSMC CMOS technology

BeamCal Read-Out

- physics data of 130 MB per bunch train: buffered and read out in 200 ms gap
 - 5 GB/s per sector for 8 sectors with 30 layers each
- beam feedback data: fast readout at 3 MHz with 2 GB/s per sector

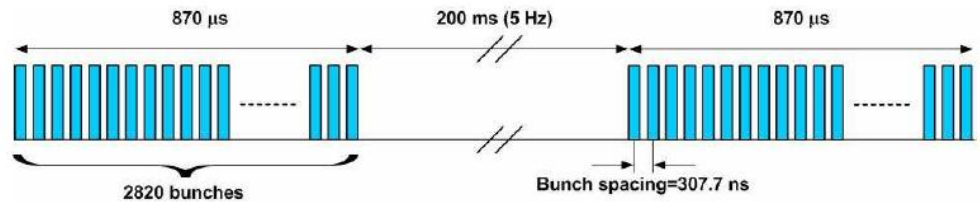

- different frontends are being discussed - connected to readout

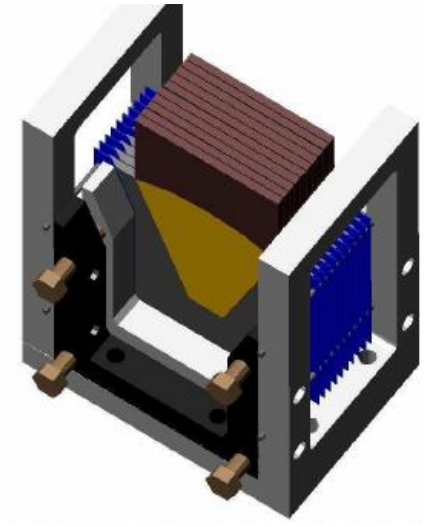
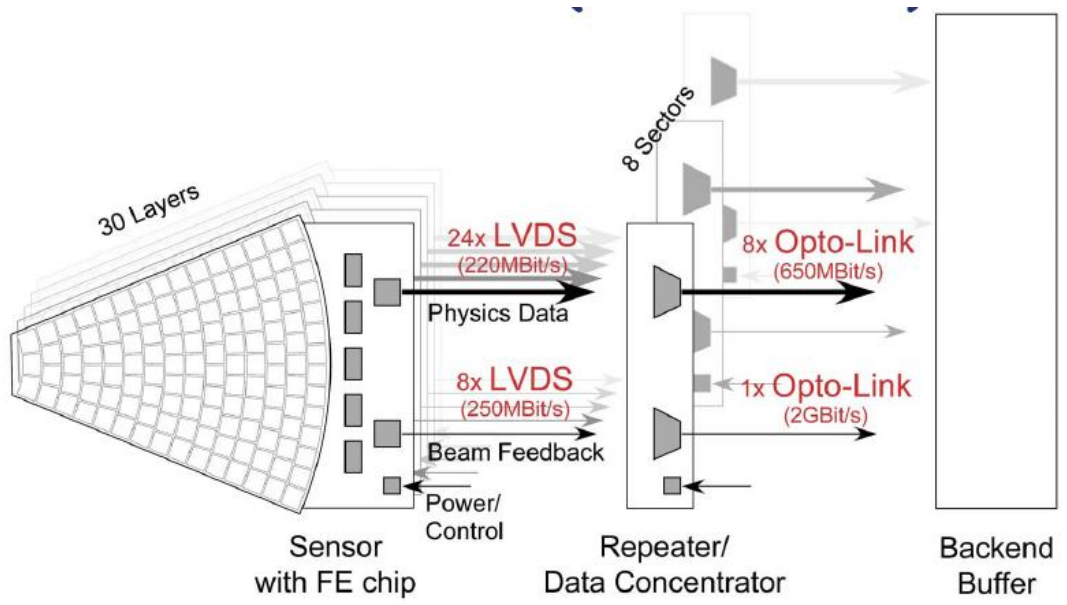

- prototype test with 1 sector 10 layers foreseen in 2012

Pair-Monitor Front-End



- ASIC for the pair monitor
- .25 μm TSMC technology
- number of pixels: 36
- Pixel size: $400 \times 400 \mu\text{m}^2$
- Prototype produced and tested

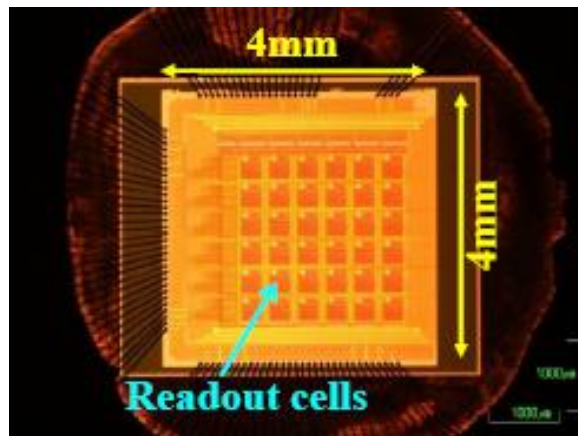

Layout of prototype ASIC

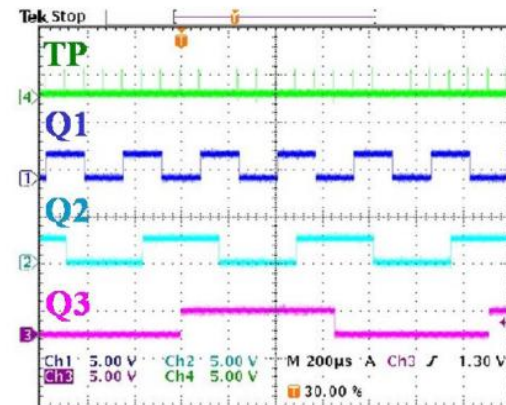
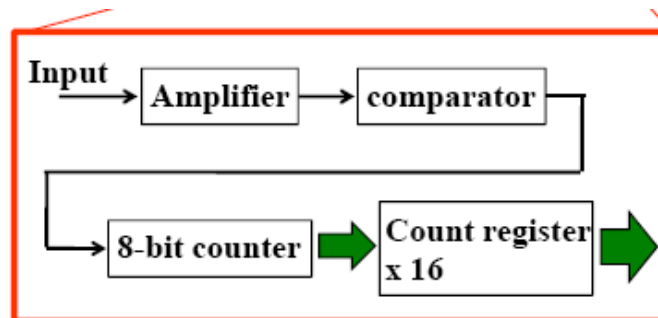
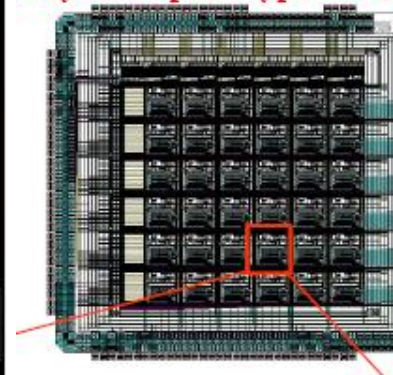

- Pair monitor will use Silicon-on-Insulator technology in next step
- prototype 2009

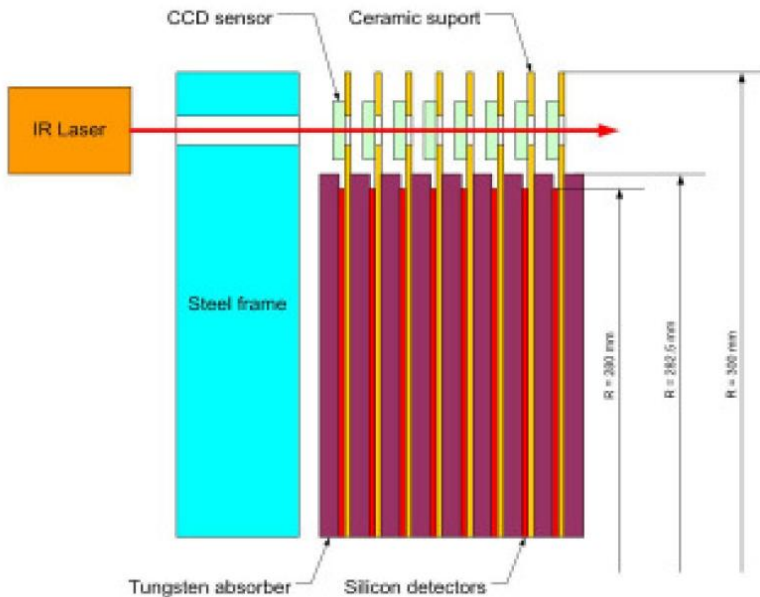
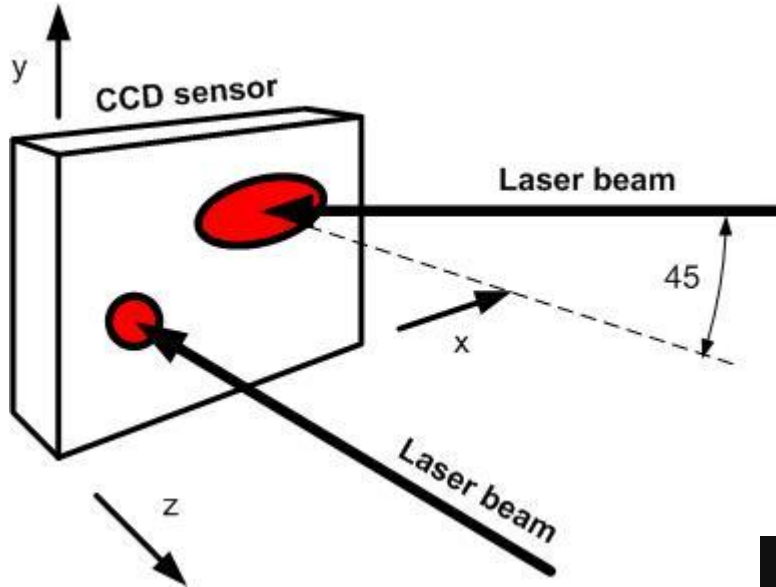

- Over short distances accuracies reached:
- Displacements in x-y plane: $\pm 0.5 \mu\text{m}$
- Displacements in z direction: $\pm 1.5 \mu\text{m}$

- FCAL R&D is actively pursued
 - In Germany mainly at DESY: sensors and readout
 - Letter Of Intend for the ILD is being prepared
 - Interesting work is ongoing
-
- thank's to the members of the FCAL collaboration for material and slides